

Cutter ICU 05 A 10

→ technical specification sheet

1

Specifications ICU 05 A 10

article number	170.012.052
working pressure	500 bar
blade type	cable
blade opening	95 mm
cutting force, max	104 kN / 10.6 t
weight, ready for use	10 kg
dimensions (LxBxH)	630 x 210 x 170 mm
temperature reach	-20° +80° C
required oil content	37 cc (effective)

Accessories ICU 05 A 10

spare blade set	170.013.068
maintenance set, cylinder	170.013.026
maintenance set, control handle	170.013.050
torque wrench, 40-200 Nm	150.581.671
cap hexagon 36 mm	170.182.005

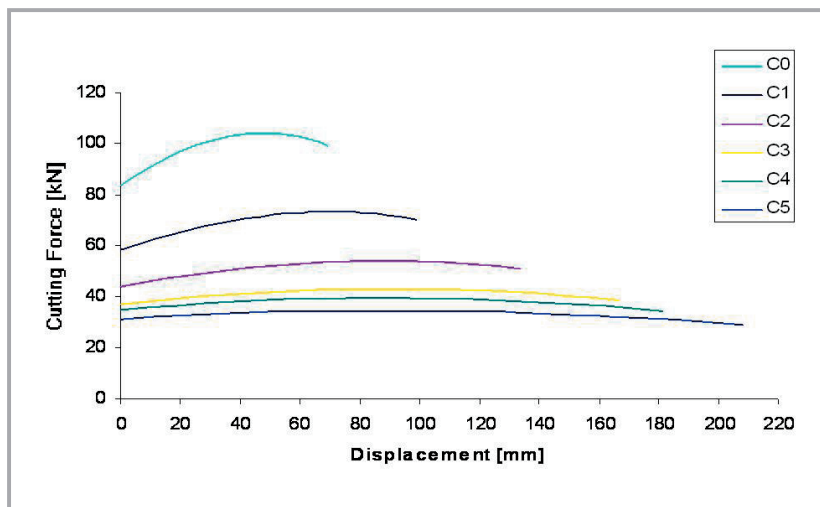
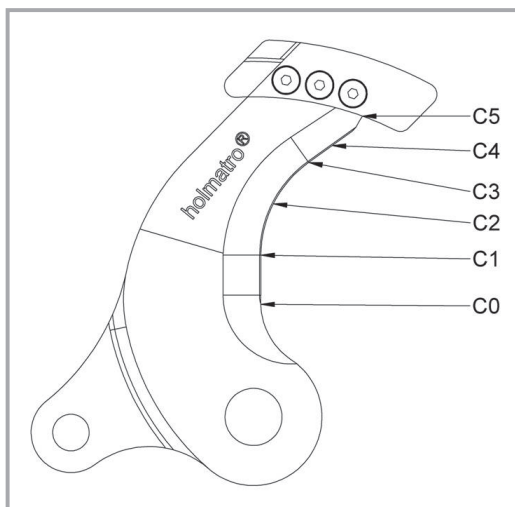

www.holmatro.com